

Velodyne LiDAR™ Puck Hi-Res™

HIGH RESOLUTION REAL-TIME 3D LiDAR SENSOR



Puck Hi-Res

Velodyne LiDAR's Puck Hi-Res is a higher resolution version of the Puck and used in applications that requires greater resolution in the captured 3D image. The Puck Hi-Res has identical performance to VLP-16 with the only differences in the vertical field of view (FoV) which is 20° instead of 30° and therefore a tighter channel distribution where it is 1.33° instead of 2.00° between channels. No other changes have been made to Puck Hi-Res as it retains its patented 360° surround view to capture real-time 3D LiDAR data that includes distance and calibrated reflectivity measurements.

Higher Resolution at Longer Distances while Maintaining High Point Density

The Puck Hi-Res has a range of 100 m with dual return mode to capture greater detail in the 3D image at longer ranges while the power consumption is approximately 8 W. A compact footprint (Ø103 mm x 72 mm) with closer spacing between channels to enable greater resolution of 3D images, the Puck Hi-Res provides more detailed views in applications such as autonomous vehicles, surveillance and 3D mapping/imaging.

It supports 16 channels and generates 300,000 points/second from a 360° horizontal field of view and a 20° vertical field of view with ±10° from the horizon. The Puck Hi-Res has no visible rotating parts and is encapsulated in package that allows it to operate over a wide temperature range (-10°C to +60°C) and environmental conditions (IP67).



DIMENSIONS

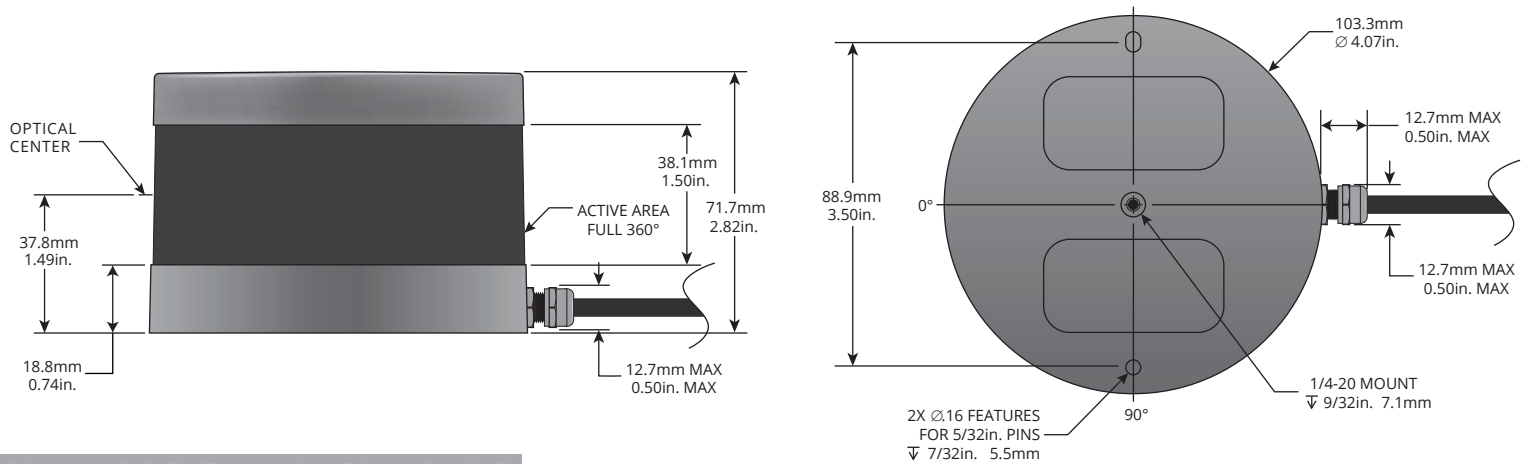

M12 CONNECTOR ON SENSOR SIDE

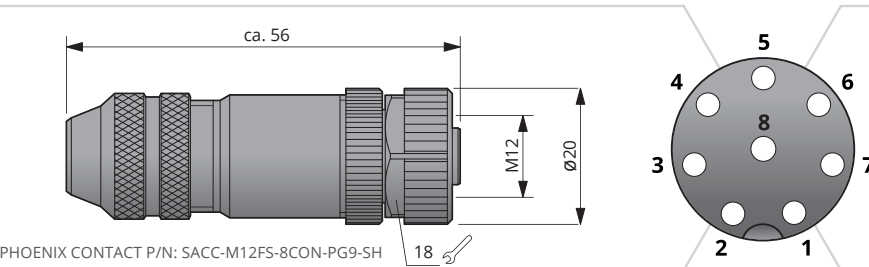

Pin	Wire Color	Function
8	Black	Ground
7	Red	+12 V
6	Yellow	GPS Pulse Per Second (PPS)
5	White	GPS Serial Data
4	Light Orange	Ethernet TX+
3	Orange	Ethernet TX-
2	Light Blue	Ethernet RX+
1	Blue	Ethernet RX-

PHOENIX CONTACT P/N: SACC-M12FS-8CON-PG9-SH



High Resolution Real-Time 3D LiDAR Sensor

The Puck Hi-Res provides high definition 3-dimensional information about the surrounding environment.

Specifications:

Sensor:

- Time of Flight Distance Measurement with Calibrated Reflectivities
- 16 Channels
- Measurement Range: Up to 100 m
- Accuracy: ± 3 cm (Typical)
- Single and Dual Returns (Strongest, Last)
- Field of View (Vertical): $+10.0^\circ$ to -10.0° (20°)
- Angular Resolution (Vertical): 1.33°
- Field of View (Horizontal): 360°
- Angular Resolution (Horizontal/Azimuth): $0.1^\circ - 0.4^\circ$
- Rotation Rate: 5 Hz – 20 Hz
- Integrated Web Server for Easy Monitoring and Configuration

Laser:

- Laser Product Classification: Class 1 Eye-safe per IEC 60825-1:2007 & 2014
- Wavelength: 903 nm
- Beam Size @ Screen: 9.5 mm x 12.7 mm
- Beam Divergence: 0.18° (3.0 mrad)

Mechanical/ Electrical/ Operational

- Power Consumption: 8 W (Typical)
- Operating Voltage: 9 V – 18 V (with Interface Box and Regulated Power Supply)
- Weight: 830 g (without Cabling and Interface Box)
- Dimensions: 103 mm Diameter x 72 mm Height
- Shock: 500 m/s² Amplitude, 11 ms Duration
- Vibration: 5 Hz to 2,000 Hz, 3 G_{rms}
- Environmental Protection: IP67
- Operating Temperature: -10°C to $+60^\circ\text{C}$
- Storage Temperature: -40°C to $+105^\circ\text{C}$

Output:

- 3D LiDAR Data Points Generated:
 - Single Return Mode: ~300,000 points per second
 - Dual Return Mode: ~600,000 points per second
- 100 Mbps Ethernet Connection
- UDP Packets Contain:
 - Time of Flight Distance Measurement
 - Calibrated Reflectivity Measurement
 - Rotation Angles
 - Synchronized Time Stamps (μs resolution)
- GPS: \$GPRMC NMEA Sentence from GPS Receiver (GPS not included)

63-9318 Rev-B

Product Ordering Information:

Product Name	SKU Ordering Number	Sensor		Interface Box			
		Connector	Cable Length	Included	Connector to Sensor	Cable Length	I/O Connectors
Puck Hi-Res	80-VLP-16-COB13P20SR4SL	None	3.0 m	Yes	None	-	RJ45, GPS and Power
Puck Hi-Res	80-VLP-16-COB13P20SM1SL	M12 Female	0.3 m	Yes	M12 Male	1.6 m	RJ45, GPS and Power



CLASS 1 LASER PRODUCT

Specifications are subject to change without notice. Banner image courtesy of Local Motors, Inc. Other trademarks or registered trademarks are property of their respective owners.